

VTC 100

ARM® Cortex™-A8 Fanless In-Vehicle Computer



Main Features

- Compact and fanless design
- ARM® Cortex™-A8 Processor with 720MHz frequency
- Variety Wireless communication options
- Built-in CAN Bus V2.0b; Optional support for J1939/J1708
- Wide range DC input from 9~ 36V
- Smart power management with Ignition on/off delay via software Control and low voltage protection
- Operating System Support WEC 7 and Linux 3.2 driver

Product Overview

VTC 100, a compact rugged computer box, is designed for the transportation segment, especial for the vehicle with limited space to house the computer system. Same as all VTC series, the fanless and wide temperature support are reserved in VTC 100 design. VTC 100 adopts the Cortex™-A8 Processor with 720MHz frequency. VTC 100 does not compromise with its space to scarify its functional features. An advanced GPS receiver with dead reckoning is available as an option as well as the wireless communication. VTC 100 is the best choice with the cost effective solution for your vehicle application.

Specifications

MPU

- ARM® Cortex™-A8 Processor with 720MHz frequency

Memory

- On-board DDR2 256MB

Expansion

- 1 x CAN Bus module with J1939/ J1708 for option
- 1 x Mini-PCIe socket (USB) x 1 for WWAN option
- 1 x Bundle GPS module

I/O Interface-Front

- 2 x USB 2.0 host type A connector
- 1 x Line-out, 1 x Mic-in
- 1 x System reset button
- 2 x LED's for power, storage
- 1 x Power button
- 1 x SIM card socket
- 4 x Antenna hole reserved for SMA-type antenna connector (WWAN/ WLAN)

I/O Interface-Rear

- 1 x 9~36VDC input with Ignition and 6W typical power consumption
- 1 x DB9 RS-232 (COM1)
- 1 x DB9 RS-485 (COM2)
- 1 x DB9 female connector for 3GPI and 3GPO
- 1 x DB15 VGA
- 1 x RJ45 with LEDs for 10/ 100/ 1000Mbps Ethernet
- 1 x SMA-type GPS antenna connector
- 1 x Antenna hole reserved for SMA-type antenna connector (WWAN/ WLAN)

Expandable Storage

- Micro SDHC Slot (Bundle with 4GB)

Power Management

- Selectable boot-up & shut-down voltage for low power protection
- HW design ready for 8-level delay time on/ off at user's self configuration
- Power on/ off ignition, software detectable

Operation System

- Windows Embedded Compact 7
- Linux 3.2

Dimensions

- 180mm (W) x 110mm (D) x 45mm (H)
- 0.5 Kg (1.10 Lb)

Dimension Drawing

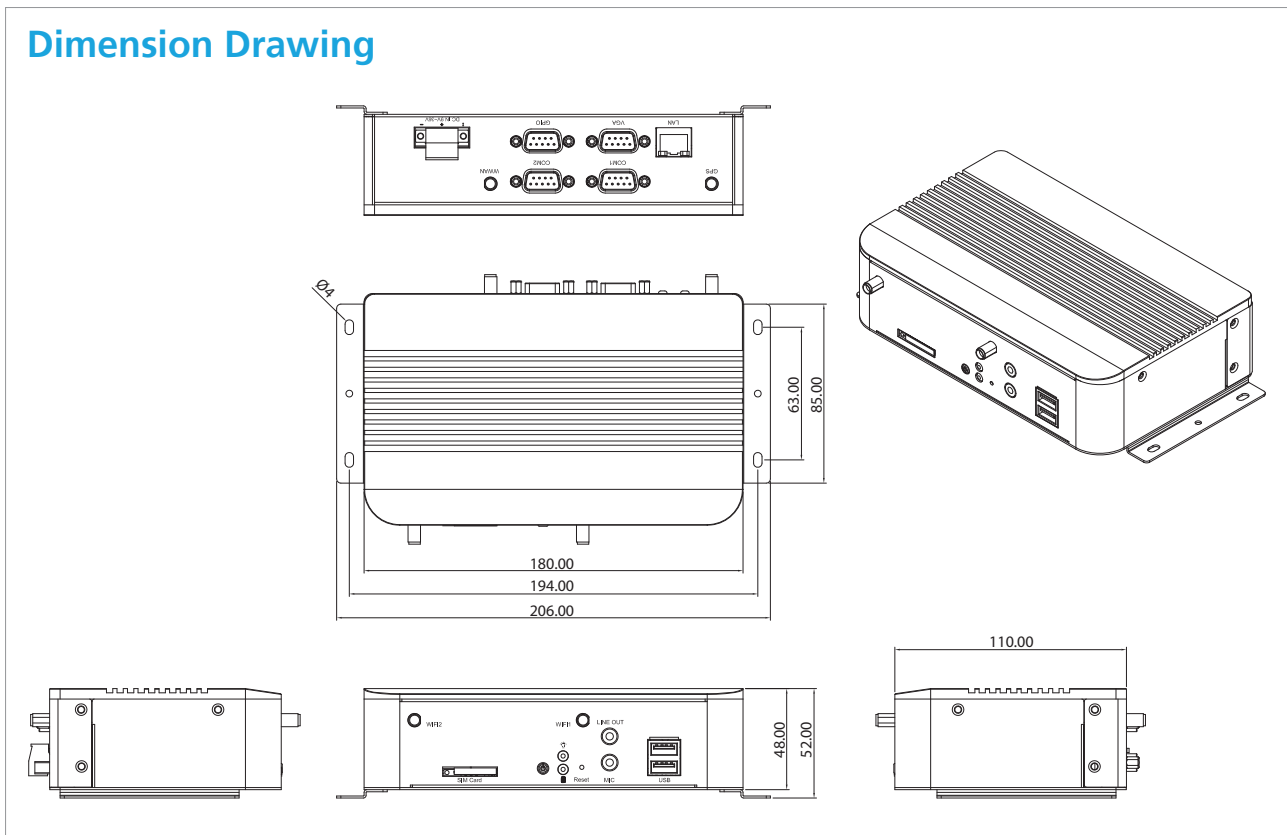

Construction

- Aluminum top case with metal sheet

Environment

- Operating temperatures
 - Ambient with air: -20°C to 70°C
- Storage temperatures: -40°C to 80°C
- Relative humidity: 10% to 90% (non-condensing)
- Vibration (random): 2g @5~500 Hz
- Vibration:
 - Operating: MIL-STD-810G, Method 514.6, Category 20, Ground Vehicle – Highway Truck
 - Storage: MIL-STD-810G, Method 514.6, Category 24, Integrity Test
- Shock:
 - Operating: MIL-STD-810G, Method 516.6, Procedure I, Trucks and semi-trailers= 20g
 - Crash hazard: MIL-STD-810G, Method 516.6, Procedure V, Ground equipment= 75g

Standards/ Certifications

- CE approval
- FCC Class B

Ordering Information

- **VTC 100-A0E (P/N: TBD)**
ARM® Cortex™-A8 720MHz Processor with 256MB DDR2 and WEC7 system
- **VTC 100-A1E (P/N: 10V00010000X0)**
ARM® Cortex™-A8 720MHz Processor with 256MB DDR2, GPS and WEC7 system
- **VTC 100-A1U (P/N: 10V00010001X0)**
ARM® Cortex™-A8 720MHz Processor with 256MB DDR2, GPS and Linux Ubuntu
- **VTC 100-A5E (P/N: TBD)**
ARM® Cortex™-A8 720MHz Processor with 256MB DDR2, GPS, CAN bus and WEC7 system